

Heirloom Tool Chest

This classic chest
offers a lesson
in efficient
woodworking

BY CHRIS GOCHNOUR

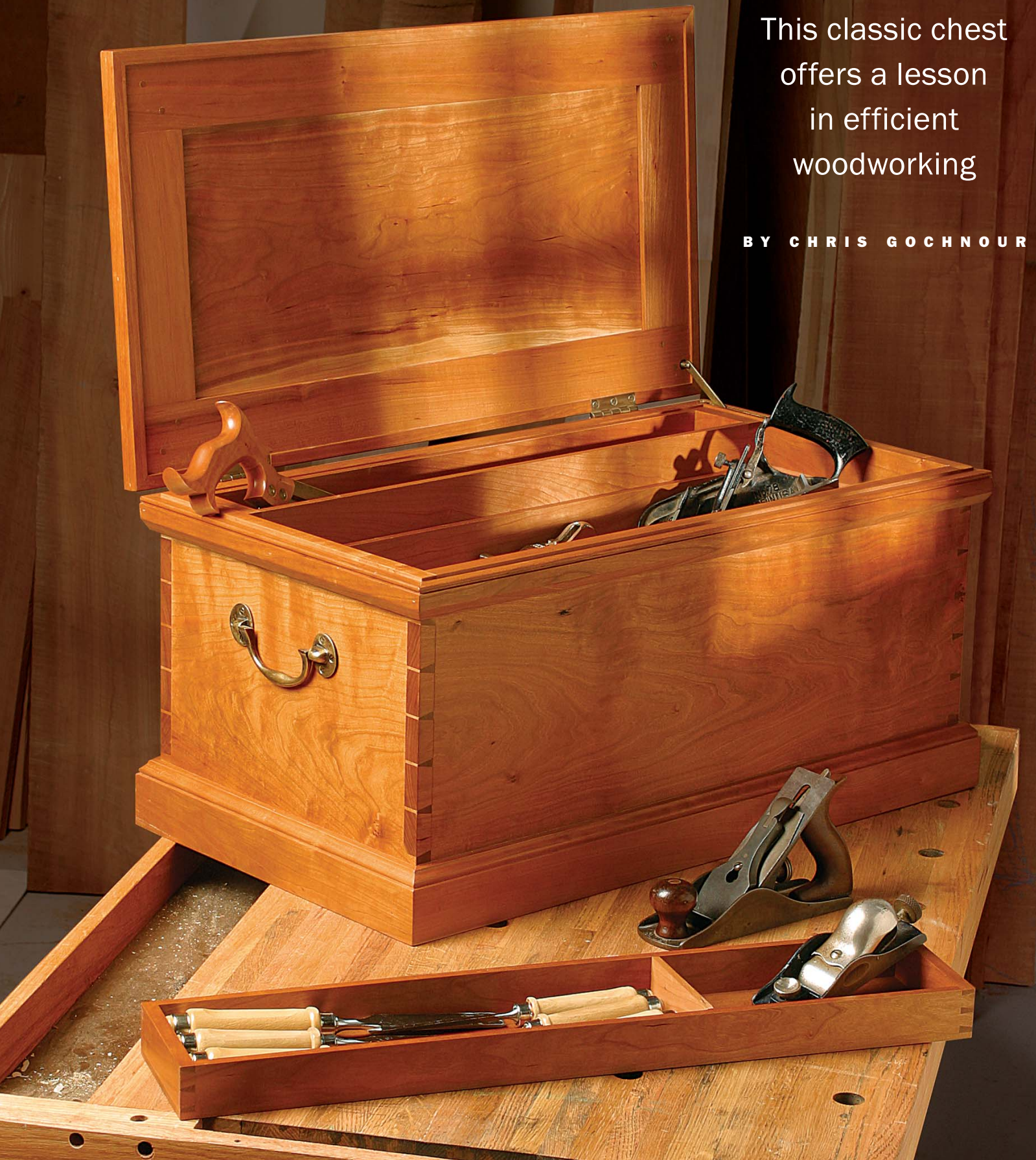

A COMFORTABLE HOME FOR TOOLS

Made of cherry and constructed entirely with hand tools, the tool chest incorporates dovetail joinery, frame-and-panel construction, and applied molding.

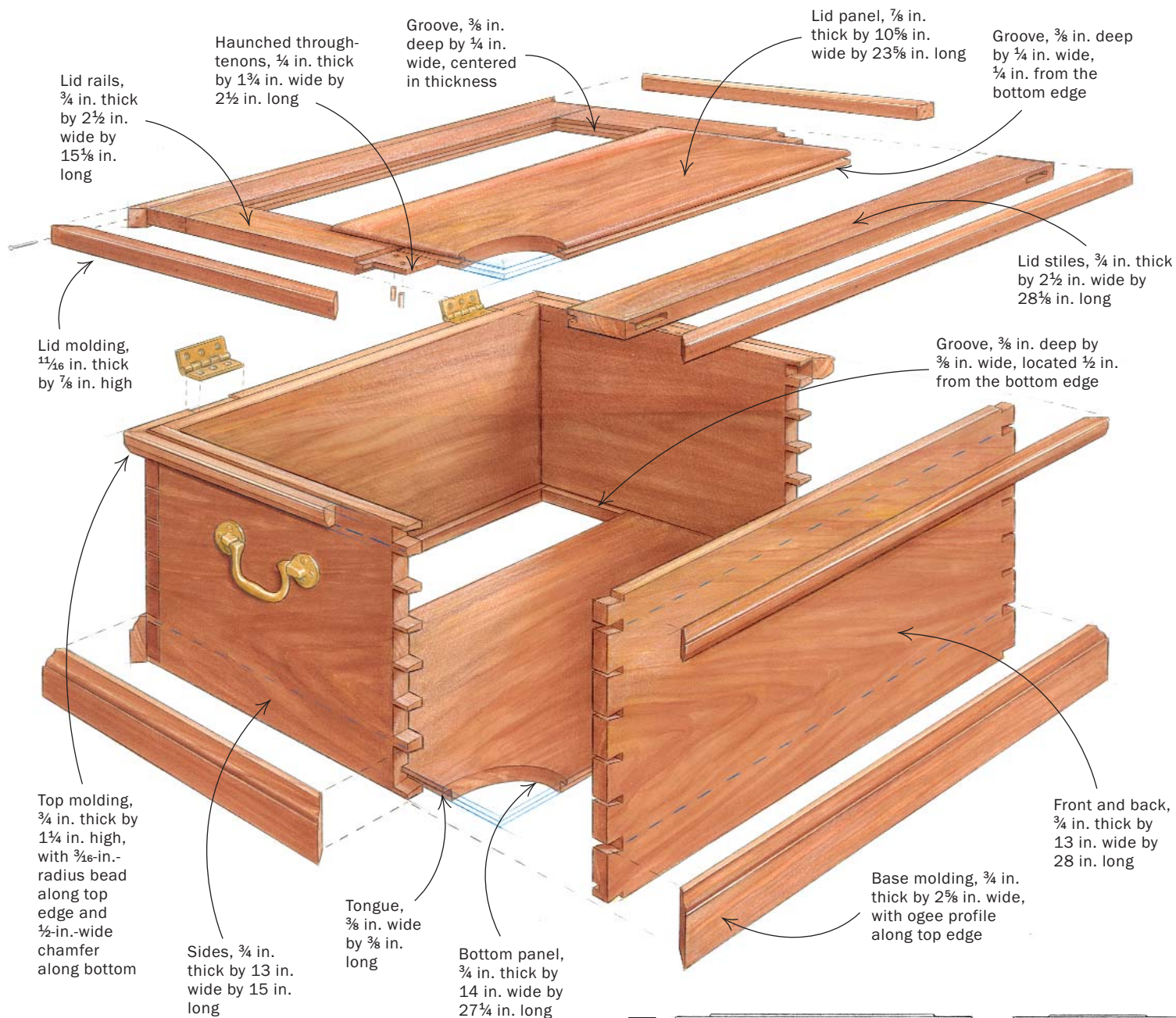

A cabinetmaker's tool chest embodies a certain nostalgia and charm for modern woodworkers. It speaks of a time when craftsmen had few tools but an abundance of skill. Tool chests often served as a calling card to display a craftsman's talents. However, some were utilitarian, built simply to house tools.

The tool chest described in this article is of the latter kind—practical, enduring, and simple. But in a time when woodworkers have an abundance of power tools at every turn, making this tool chest with traditional hand-tool techniques can be a bridge to an era past. I recommend using this project as a hand-tool exercise, though power tools could be substituted for any of the operations. Practicing the techniques involved in the chest's construction will

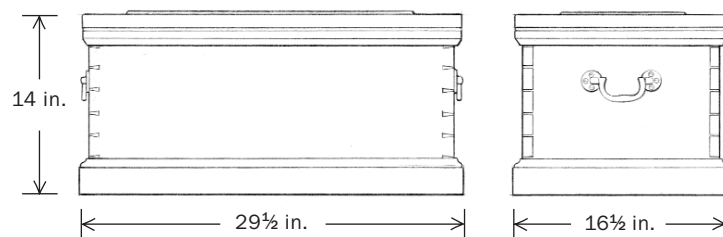

make you more confident with hand tools, and you may find them an indispensable resource in your day-to-day shop tasks.

Choose and mark the material

Select a medium-density hardwood that is worked easily with hand tools. Because the tool chest is intended to be carried,

DOVETAIL AND ASSEMBLE THE CASE

Cut the tails. Clamp both the front and back of the chest in a vise with the inside faces touching (right). Make the cuts with a backsaw. Next, clean out the waste one board at a time with a coping saw (below). Make sure you do not cut past the scribe line.



choose wood that is lightweight yet durable. For this box I chose cherry, which is easy to work and attractive; however, woods such as red alder, poplar, and white pine also are appropriate.

To reduce the likelihood of warp and twist, select clear, straight-grained wood for the lid frame. This type of wood also is good for the moldings because it will make them easier to work with molding planes. Knots are fine on panels, but keep them away from the edges so that they will be out of the way of the joinery.

Once you've dimensioned the lumber for each part, mark them with cabinetmaker's triangles (see *FWW* #149, p. 90, 92). These triangles clearly identify the face and the inside and outside edges of each part. And they are helpful for identifying the orientation of the pieces when you begin cutting joints.

From here, follow a sequential pattern of construction: Join the box using dovetails; build the frame-and-panel lid with mortise-and-tenon joinery; shape and apply moldings; and install the hardware.

Practice and plan the carcass dovetails

I tell students that making dovetails is easy, but controlling a handsaw can be difficult. Get comfortable using a handsaw before you undertake the dovetails, and practice dovetail-like cuts on scraps of wood to improve your skill.

Clear and accurate layout is essential to hand-cutting dovetails. Much of your success will come down to your layout and your ability to work to the lines and never cut beyond, which comes with practice. The objective is to cut precisely to the layout lines each step of the way. This will greatly minimize cleanup and fitting, making the entire process more efficient and enjoyable.

Cut the tails two boards at a time—I cut the tails first and then use them to lay out the pins.



Chop to the baseline with a chisel. Use a block of wood, securely clamped along the scribe line, to guide the chisel. Chop partway from both sides of the board to avoid tearout.

I also cut the tails on the front and back of the chest at the same time with the two boards clamped together in a vise. It is faster and more accurate because the saw has a longer line to follow as you make the perpendicular cut along the end grain. Check your cabinetmaker's triangles to see whether you have oriented the boards correctly; the inside faces of the boards should be touching.

Next, remove the bulk of the waste with a coping saw one board at a time. Finally, chop to the baseline with a chisel. This is a critical step for the dovetails to fit together snug. One method I use is to guide the chisel with a block of wood clamped in place along the baseline. Chop halfway through from each side to avoid tearout.

Cut the pins to match the tails—The tails on the chest's front and back boards are used to lay out the pins. With one board secured vertically in the bench vise, place the adjoining tail board on top, carefully aligned, and secure it with a clamp.

Once again, make sure the box parts are oriented correctly, then define the pins on the end grain by tracing the tails with a marking knife. Next, deepen the marks using a broad chisel with its bevel facing the waste. This chisel mark will help guide your saw. Continue the layout line down the face of the board with a sharp pencil, stopping at the scribed shoulder line.

The pins are cut much the same as the tails; however, it is more critical here to cut to the line and not past it. With the saw resting to the inside of your chisel mark, make the vertical cuts down the waste side of the pins. Next, remove the bulk of the waste with a coping saw and pare to the baseline with a chisel.

Cut the bottom panel

The bottom panel of the chest must be sized and fitted prior to glue-up. The panel floats in a groove plowed on the inside of the sides, front, and back of the chest carcass. Use a mortise gauge to scribe two lines $\frac{3}{8}$ in.

apart, about $\frac{1}{2}$ in. from the bottom. Now plow the groove with a plow plane. The scored lines from the mortise gauge ensure a clean cut.

The chest bottom is rabbeted, leaving a $\frac{3}{8}$ -in. by $\frac{3}{8}$ -in. tongue that will be housed in the groove. Define the rabbet with two scribe lines, then remove the material between these lines with a fillister plane. Remember, the chest's bottom panel should be free to shrink and expand in the groove. Make sure it is slightly undersize, and don't glue it during assembly.

Glue up the chest carcase

Dry-fit the carcass prior to assembly to ensure that all of the dovetails fit properly and that the bottom panel has room to



Mark the pins with the tails as your guide. With the tail board clamped firmly in place, trace the tails onto the end grain of the pin board with a marking knife. Deepen the marks with a chisel to provide a kerf for the handsaw.



Glue up the carcass. After dry-fitting all of the pieces, coat the dovetail joints with slow-setting wood glue and assemble. The rabbeted bottom panel floats in the grooves plowed into the four sides. No glue is used.

APPLY THE MOLDINGS



Cut the front molding to size first. Once the front molding has been fitted and clamped to the carcass, measure and cut the side moldings to fit. The back piece is cut and fitted last.

move. I've found that the glue-up can take some time, so an extra pair of hands and slower-setting glue can be helpful.

I prepared notched cauls that fit around the dovetail pins to spread the clamp pressure evenly without getting in the way of the joinery. Four clamps evenly spaced are adequate for each side. Make sure the chest is glued up squarely, and readjust your clamps to correct any sides that are out of square.

Once the glue has dried, plane the dovetails clean and flush, and turn your attention to the chest's lid.

Through-tenons make a sturdy frame-and-panel lid

For the lid's frame, I used through mortise-and-tenons. Through-tenons make the lid stronger because they provide more glue surface, and the strong, long grain of the rails passes all the way through the weak cross-grain of the stiles. In this way, the tenon serves as a reinforcing cross-ply to the outside edge of the lid. Through-tenons also minimize the chance of twist in the frame. Because the mortises are chiseled out from both sides at the same point, it is impossible for the tenon to come through on an angle. Also, chopping all the way through the stile is faster because you don't have to clean the bottom of the mortise, a difficult task.

The lid should be $\frac{1}{16}$ in. larger than the box on all sides to provide clearance for the applied moldings. Size your stiles and rails taking this into account. Also, overcut the stiles by 2 in. to account for horns, which



A VERSATILE MITERING JIG

This simple maple jig works as a miter box, accommodating a panel saw in three positions for cutting at 90° or 45° in either direction, and doubles as a miter jack. One end is cut at 45° and is designed for fine-tuning miters with a bench plane. Once you have sawn the miter, secure the workpiece in the shooting end of the jig with a cross pin and wedge, and trim it to perfection.

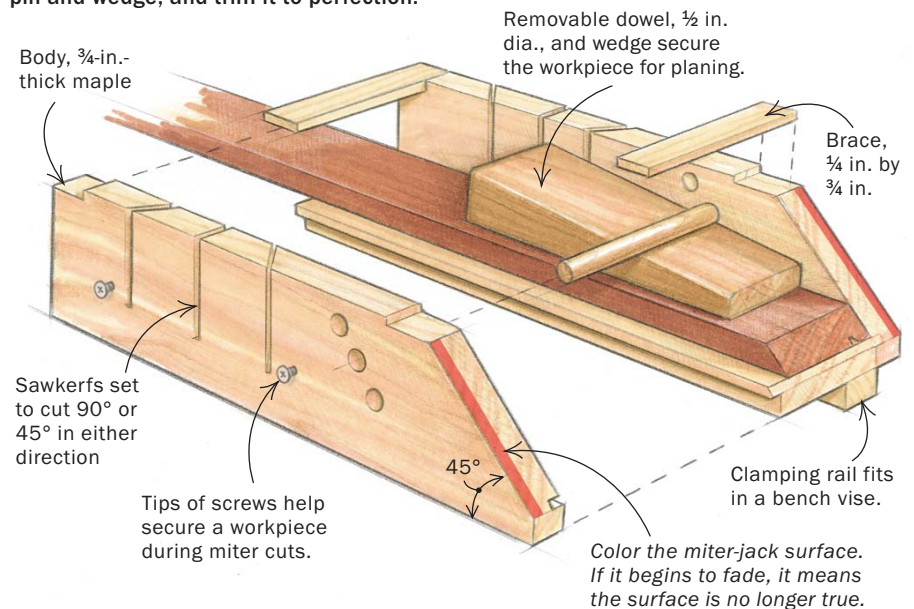

add strength to the material when cutting the mortises. The horns are trimmed off after the lid has been assembled.

One setting on a mortise gauge is used throughout—On the inside edge of the stiles, mark each end where the rails will intersect the stiles. Then measure $\frac{3}{8}$ in. from these lines and draw two more marks to define the width of the mortises. Because it is a through-mortise, the lines also must be transferred across the face to the outer edge of the stile.

Set up your mortise gauge precisely to mark the groove for the lid panel as well as the mortises and tenons. Scribe all of these lines referencing off the face of the boards. Last, lay out the tenon cheeks, haunch, and shoulders with a marking knife.

Rough-cut the haunched tenons and then chop out the mortises—Once the lines have been marked, begin rough-cutting the tenons. Cut close to the lines, but leave material for final fitting later. Then plow the groove on the inside edge of all of the stiles and rails. Be sure to reference these plow cuts off the same face of each part, guaranteeing a consistent alignment of the groove.

Finally, chisel the mortises. The key to successful mortising is to

use the right chisel—one with a thick blade to keep the chisel from twisting and a long bevel to take a shearing cut. Clamp together the two stiles in a wooden hand screw with the grooves facing up. Clamping the boards will prevent them from splitting as you chisel away the waste. Work your way through half the width of the stile on all four mortises. Then flip over the stiles and finish chopping from the other side. When you are all the way through, clear out the debris and use a paring chisel to clean up any irregularities, ensuring the mortise is straight and true on all four sides.

Once the mortises have been completed, fit the tenons. I used a paring chisel or shoulder plane to fine-tune the shoulder and a router plane set to the depth of the layout lines to fine-tune the fit of the tenons. Dry-assemble the frame, and use this as one more chance to get an accurate measurement for the panel.

Plow a groove in the panel and assemble—The panel should be sized to fit into the groove with some extra room to accommodate expansion and contraction with humidity changes. Locate and scribe a groove with the same setting on the mortise gauge as used for the frame. However, this time register off the bottom side of the panel. Then plow the groove on all four sides.

Next, shape a thumbnail molding on the panel with a block plane. Before applying glue, dry-fit the frame and panel to make



Glue the top molding. Later, after the hardware has been installed, nail the molding with finish nails to add additional holding power.

OFFSET THE MOLDINGS TO CREATE A LIPPED LID

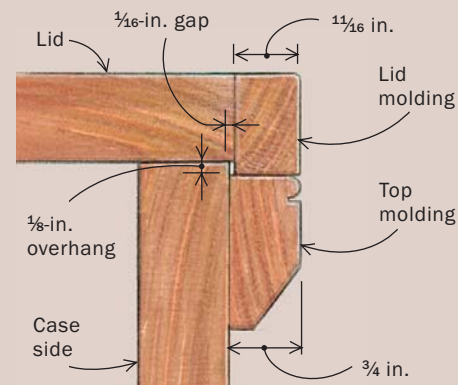

The lid molding masks minor warp or twist in the frame-and-panel. Set the lid on the box and apply the molding so that it rests on the edge of the carcass molding.

MAKE AND HANG TOOL TRAYS

The interior tool trays slide along cleats attached to the carcase sides. The sides and bottoms of the trays are $\frac{1}{4}$ in. thick. The ends of the small trays are $\frac{1}{2}$ in. thick. The ends of the saw box are $\frac{3}{4}$ in. thick and notched to fit the cleat.

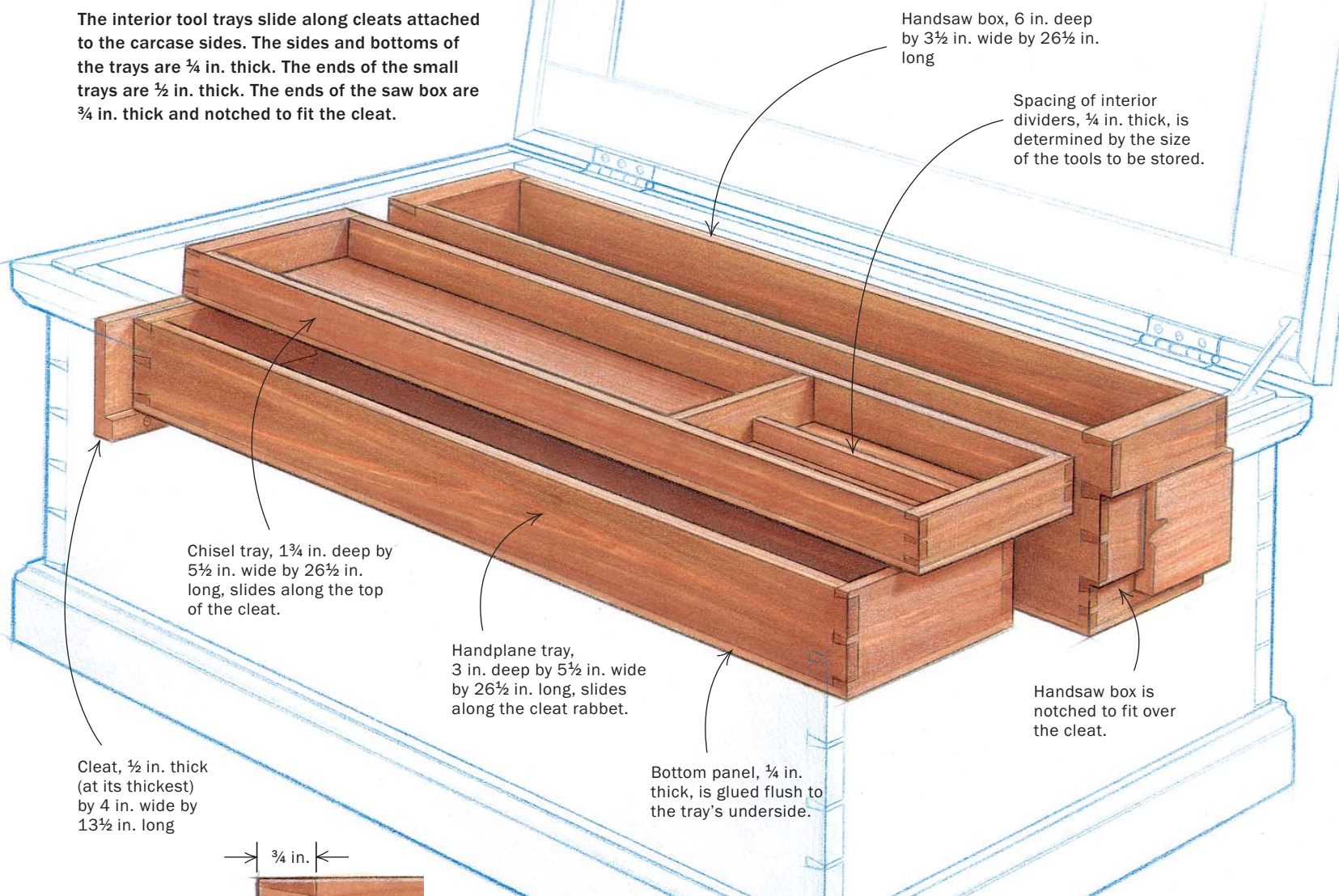

Cleat, $\frac{1}{2}$ in. thick (at its thickest) by 4 in. wide by $13\frac{1}{2}$ in. long

Chisel tray, $1\frac{3}{4}$ in. deep by $5\frac{1}{2}$ in. wide by $26\frac{1}{2}$ in. long, slides along the top of the cleat.

Handplane tray, 3 in. deep by $5\frac{1}{2}$ in. wide by $26\frac{1}{2}$ in. long, slides along the cleat rabbet.

Bottom panel, $\frac{1}{4}$ in. thick, is glued flush to the tray's underside.

Handsaw box is notched to fit over the cleat.

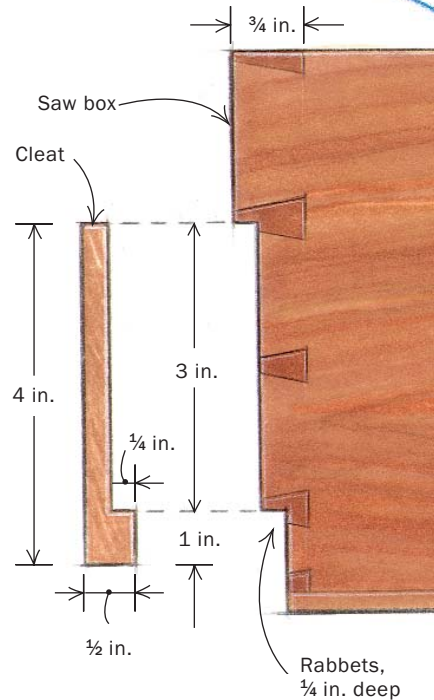

CLEAT DETAIL

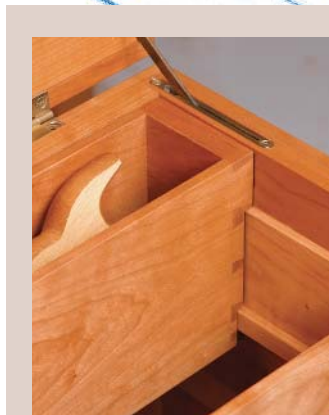

Trays slide on cleats inside the chest. Nail the cleats to the inside of the chest so that the trays slide front to back. The two shallow trays should have enough clearance to slide past each other.



sure all of the parts go together well. After gluing up the frame-and-panel lid, trim off the horns and check that the lid is square to the box and slightly oversize.

Top off the chest with molding

The molding on the tool chest is not only attractive, but it also serves practical purposes. Along the bottom it provides a bumper to protect the box as it is toted from place to place. On the top, the molding seals the chest interior, keeping it relatively free from dust and humidity.

I enjoy shaping and applying the molding because I love working with molding planes, and I like seeing the box begin to take on its final form. Molding planes are simple tools, with only a contoured wooden body and a steel blade. They don't require electricity like a router does, and the only noise they make is the sweet sound of wood being sheared from a board edge in long, continuous shavings. I enjoy the slight physical workout involved when using molding planes and the satisfaction of seeing the molding emerge from the board edge. The whole process takes me back to a time when there was nothing between the board and the craftsman but a well-tuned tool.

I milled the base molding using a molding plane with an ogee profile. A cove, quarter-round, or simple bevel profile would suit the chest just as well. I shaped the molding for the upper portion of the chest with $\frac{3}{16}$ -in. beading on its top edge and a bevel on the bottom. The band of moldings for the lid is shaped with $\frac{1}{8}$ -in. roundover, but only after it has been applied to the lid frame.

Begin by cutting miters on the front base molding until the piece fits the carcass. Then work your way around the chest measuring and cutting the side pieces and finally the rear section. Carefully fit each miter joint as you move around the chest. I used a miter jack for this (p. 40). Apply the moldings first with glue and clamps, and then secure them later with finish nails, being careful not to put nails

where the hinges and lid stay will be installed. Follow this series of steps to install the lid and the lid moldings.

Build the sliding trays to fit

Because this tool chest is such a personal item, the inner tray system can be personalized, too. I designed mine with three removable sliding trays, which hold saws, chisels, handplanes, and a host of other hand tools. The tray boxes are dovetailed, and the bottom of each tray is glued flush in place. Two stepped cleats tacked onto the inner sides of the chest support the trays, allowing them to slide forward and backward on different planes.

Install hardware and finish

Finish off the tool chest by installing the brass hardware, which consists of two 90° stopped handles, two mortised hinges, and a lid stay (Whitechapel Ltd.; 800-468-5534). The hinges are screwed onto the molding, which is why it's a good idea to reinforce the molding with a few finish nails once the hardware has been installed.

I finished the chest with three coats of Tried and True oil/varnish blend applied over several days, scuff-sanding between coats. Tool chests often get abused, so I avoid built-up finishes such as shellac or lacquer, which are prone to scratching and scuffing. But painting the chest would not be out of character with traditional tool chests. Use a flat acrylic latex paint, which imparts a look similar to milk paint, and top it off with a thin shellac topcoat. □

Chris Gochnour makes custom furniture in Salt Lake City, Utah.



Dovetailed trays hold hand tools. The three trays are sized specifically to hold Gochnour's chisels, planes, saws, and various other hand tools. The sides are dovetailed, and the bottom panels are glued flush to the trays.

